

infeed plants and means of charging

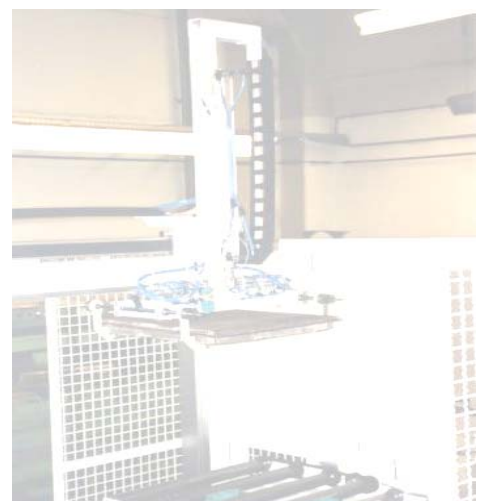

- manipulator / robots
- vibration conveyors
- roller tables / chain conveyors
- pusher-type conveyor
- furnace grids

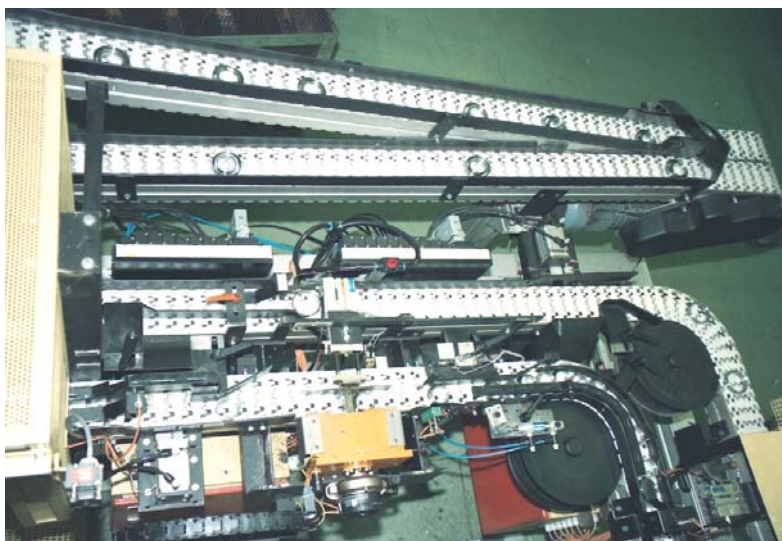

furnace manipulator

technical data:

charge dimensions: 500 x 500 x 250 mm
charge weight: 50 kg
lift x-axle: 2500 mm
lift z-axle: 600 mm

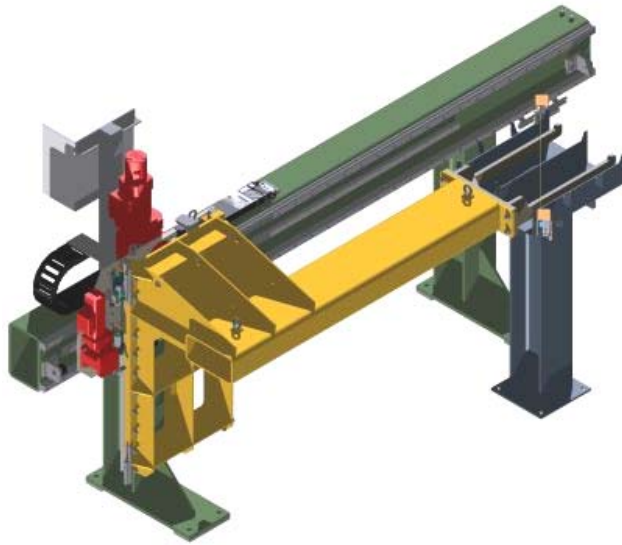

hardening tester (manipulator)



cross carriage

technical data:

charge dimensions: 1200 x 1700 x 250 mm
charge weight: 500 kg
two separately driven roller tables with adjustment device

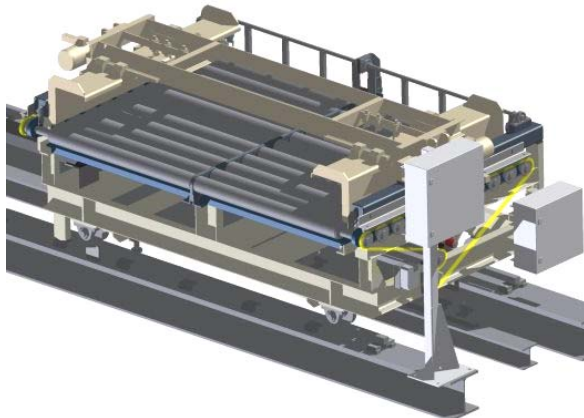

lift chain conveyor

technical data:

charge dimensions: 1200 x 1700 x 250 mm
charge weight: 500 kg
10-string chain conveyor
three integrated roller tables with adjustment device and separator

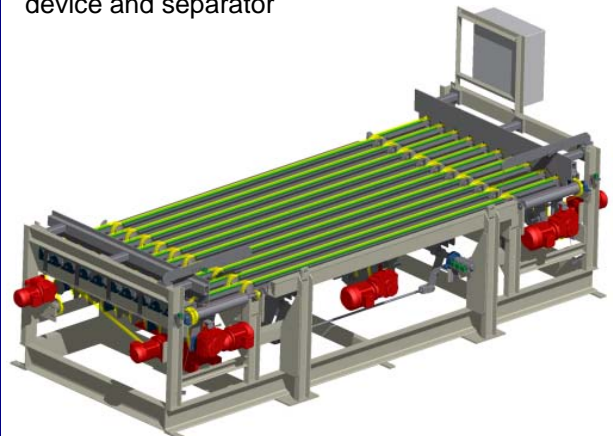

roller table with chain conveyor

technical data:

charge dimensions: 300 x 250 x 100 mm
 charge weight: 40 kg
 optional with portal

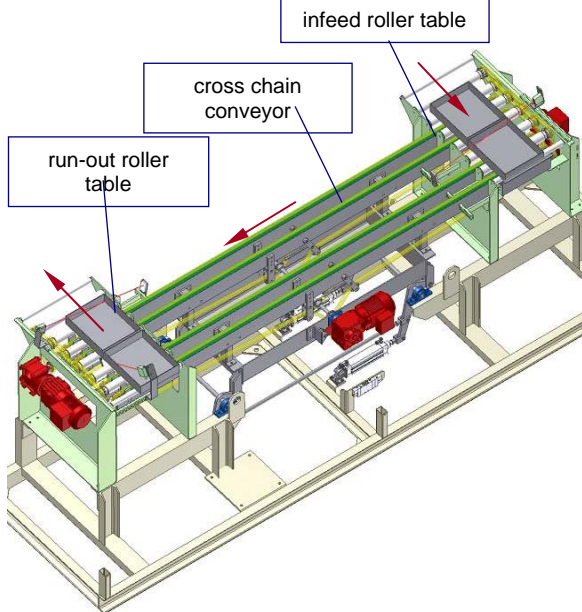

elevator

technical data:

charge dimensions: 500 x 500 x 200 mm
 charge weight: 50 kg
 lift z-axis: 4500 mm

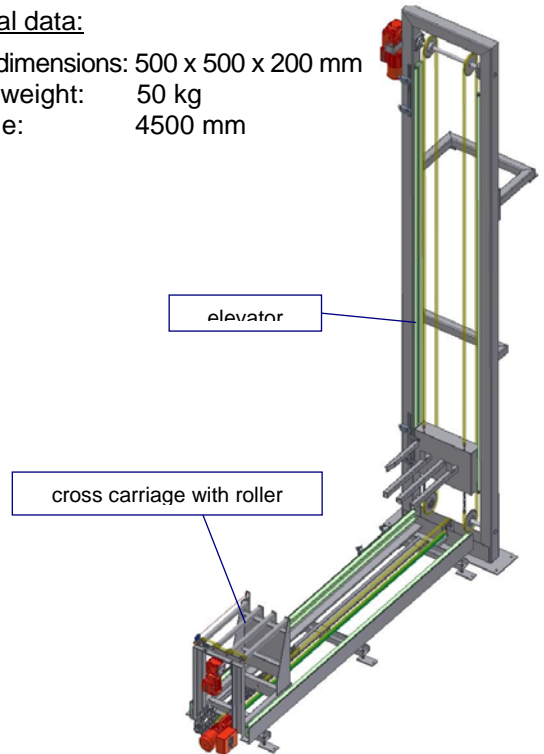

upload chain conveyor

technical data:

charge dimensions: 2000 x 200 x 1000 mm
 charge weight: 2000 kg

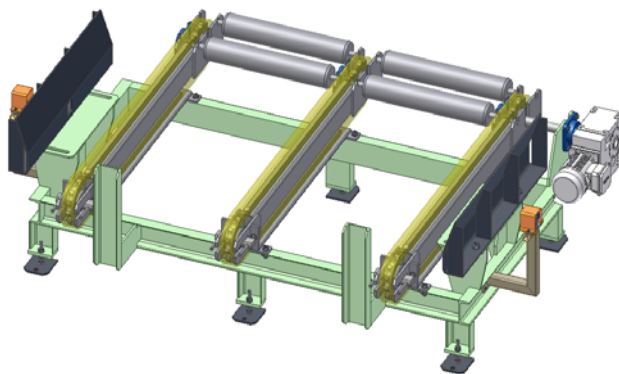

pusher-type conveyor

technical data:

charge dimensions: 650 x 650 x 650 mm
 charge weight: 400 kg

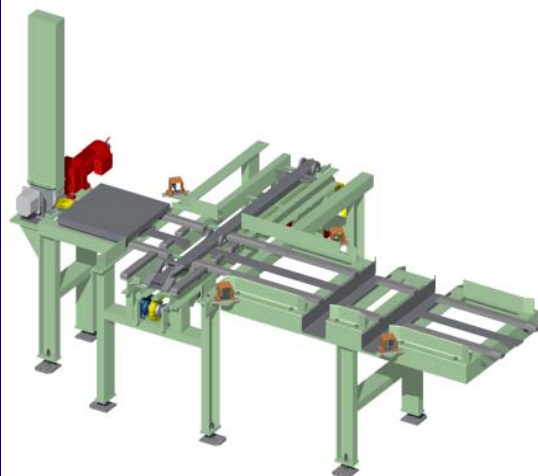

furnace grids

dimensions: 2000 x 1000 x 2000 mm
temperature: up to 550°C
up- and unloading with robots

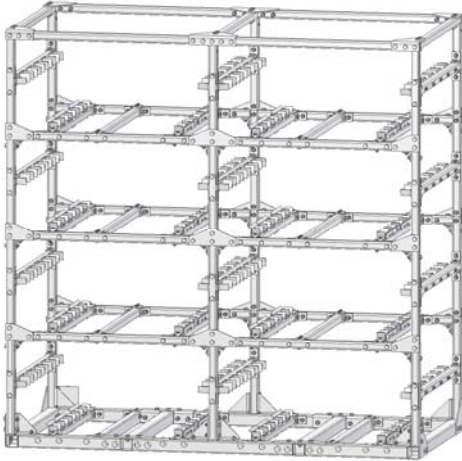

dimensions: 2000 x 1000 x 2000 mm
temperature: up to 550°C
5-fold stackable
up- and unloading with robots

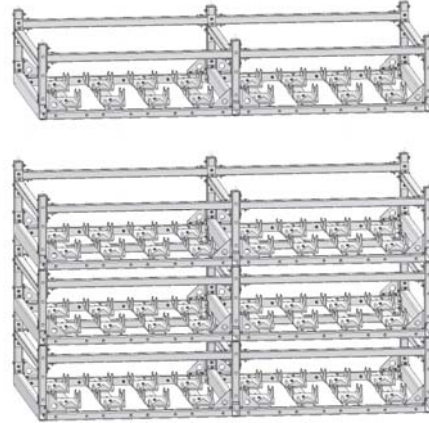

plug-in board for basic grid:

dimensions: 300 x 400 x 30 mm
temperature: up to 1100°C



basic grid:

dimensions: 1300 x 910 x 870 mm
temperature: up to 1100°C



grid:

dimension: 260 x 240 x 45 mm
temperature: up to 900°C

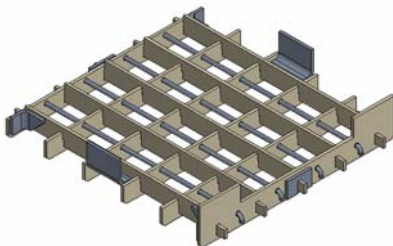

furnace basket:

dimension: 300 x 300 x 30 mm
temperature: up to 900°C
optional with cover plate

